

TPL200

Multi-Frequency Locator **User Manual**

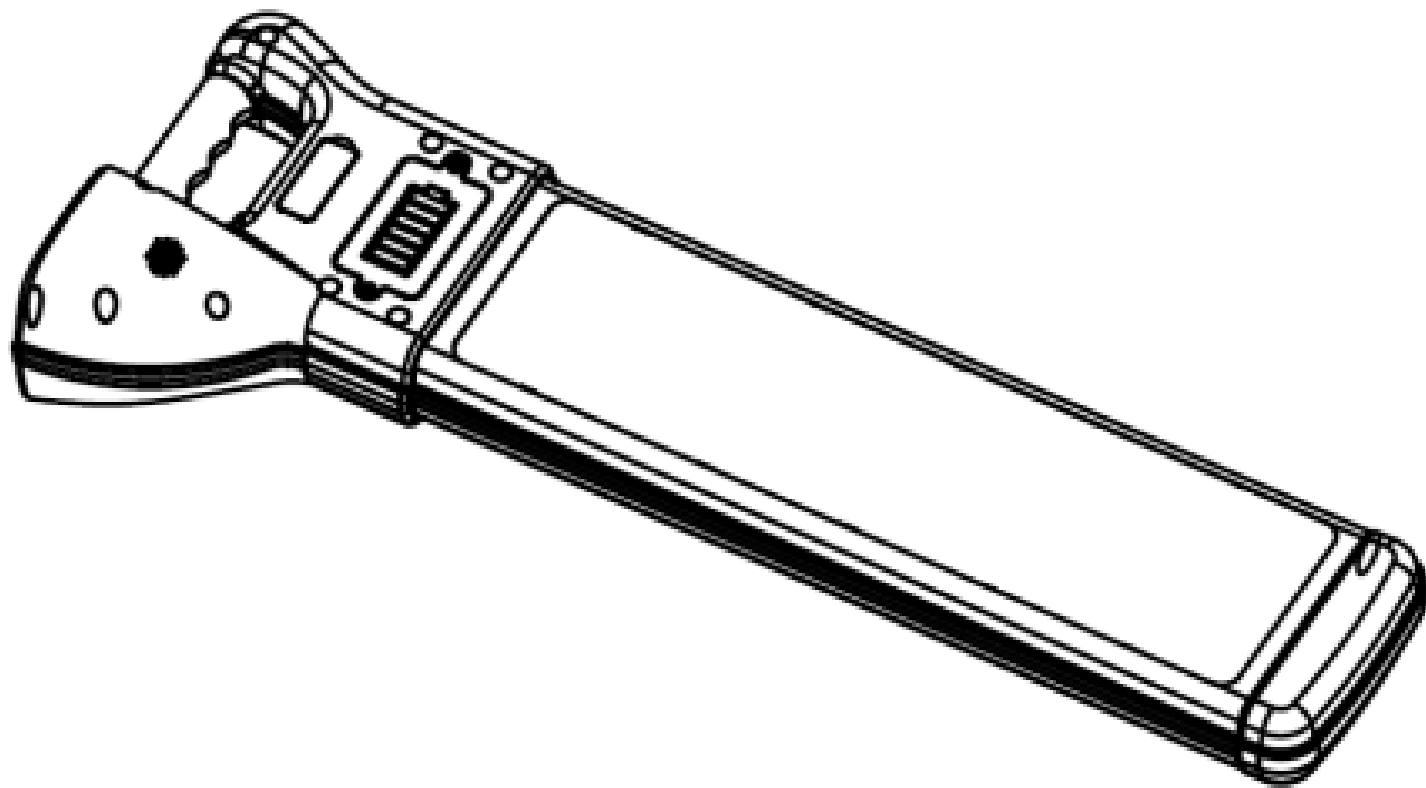

Read this manual before using your equipment. Always keep it with the equipment for future reference.

Thanks for purchasing the Multi-Frequency Locator. The Locator is designed to locate buried pipes and cables. The Locator will help you locate and trace the routes of buried power cables, drain, duct, pipes, sewer lines, and telephone cables. The locator can be use alone, or used together with camera sonde or transmitter.

Notes: The Locator cannot be used as a Metal Detector

- Passive: 50 / 60Hz Power Cable and Radio

Usually, signals are already present in buried cable and can be readily detected by the Locator. These signals are generated by power distribution systems or communication in cable.

- Active: 512Hz, 640Hz, 33KH

Some pipes and drains do not have cables. Usually put a sonde or transmitter inside the pipe. Signals will be generated by sonde or transmitter inside the pipes.

Supplied Components

1. Multi-Frequency Locator
2. User Manual
3. TYPE-C to USB-A Charging Cable
4. 7.4V 2200mAh Li-Ion battery package (Built-in)

Specification

Frequency	512Hz, 640Hz, 32.768kHz, Power-50Hz, Power-60Hz, Radio (6KHz-22KHz)
Battery Capacity	7.4V 2200mAh Li-Ion battery package (Built-in)
Work Current	100mA (Approx.)
A Single Charge Work Time	18 Hours (Approx.)
Charging	DC 5V 1A
Charge time	3 hours
Signal strength	LCD bar graph and sound volume. Relative Digital Signal Strength readout from 0% to 99.9%
Gain control	Up/down button for automatic centering, or manual control.
Water-Proof	Ip64
Dimensions	69.0 x 24.5 x 11.0 cm (L x W x H)
Operating Temperature	-10°C to +50°C (14°F to 122°F)
Weight	2.0 kg

Safety

This equipment shall be used only by fully qualified and trained personnel, and only after fully reading this Operation Manual.

This equipment will not be permanently damaged by reasonable electrostatic discharge; however, in extreme cases temporary malfunction may occur. If this happens,

switch off, wait and switch on again. If the instrument still malfunctions, disconnect the batteries for a few seconds.

WARNING: Reduce audio level before using headphones to avoid damaging to your hearing.

WARNING: This equipment is NOT approved for use in areas where hazardous gases may be present.

WARNING: Exposing the battery to a high temperature above 60°C (140°F) may cause a permanent battery failure.

Basic interface

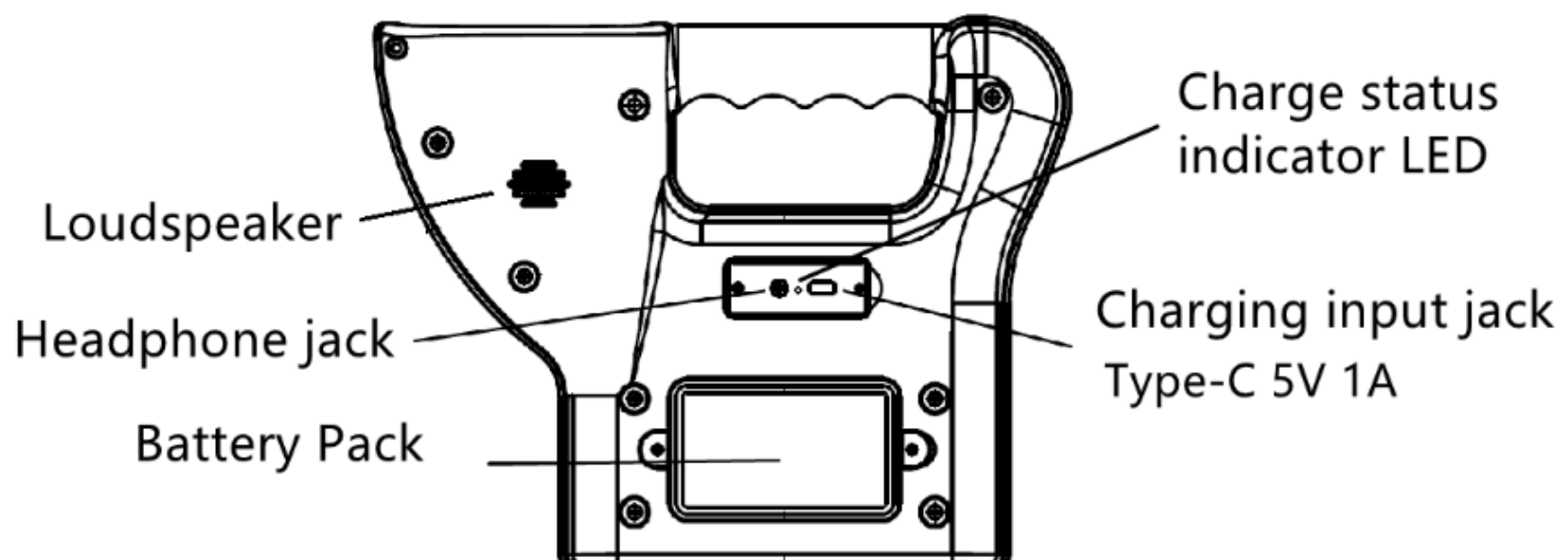

Display and Function keys

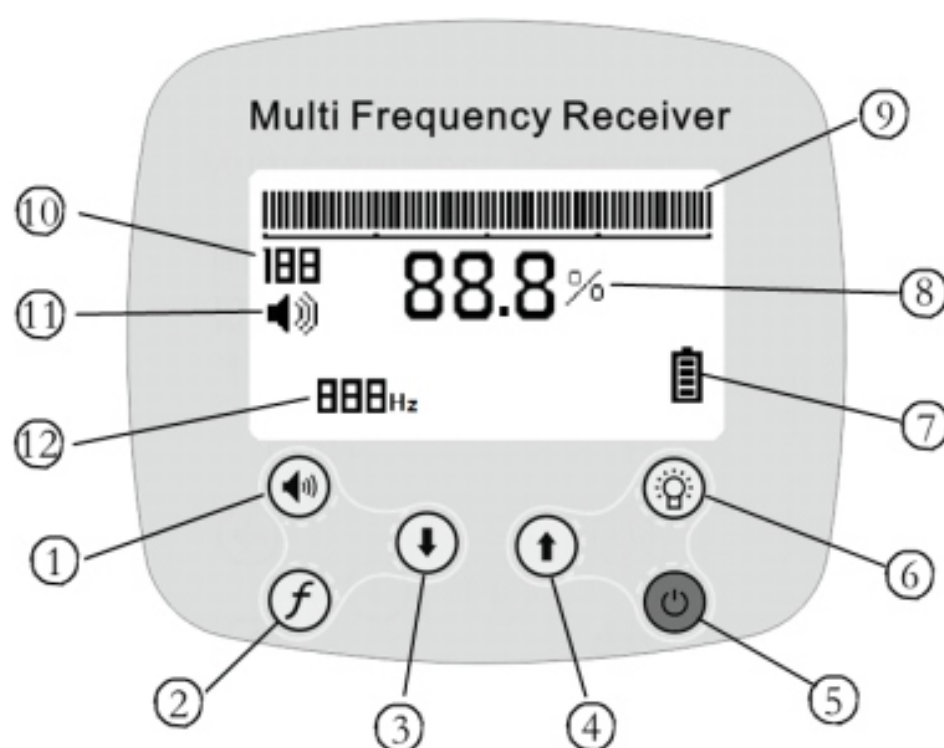

- (1) Speaker Volume. Set speaker volume level (off, low, mid, high).
- (2) Frequency Key. Select the frequency. Ensure that the Locator frequency is set to be the same as power cable, sonde or transmitter.
- (3) Gain down Key. Decreases the signal gain, press and hold down the Gain down Key to quickly decrease the signal gain.
- (4) Gain up Key. Increases the signal gain, press and hold down the Gain up Key to quickly increase the signal gain.
- (5) On/Off key. Press and hold more than 2s to power on/off the Locator.

Notes: When no key is pressed, the Locator will automatically shut down after 10 minutes.

Frequency and Volume settings will be saved when the Locator is powered off.

- (6) Backlight Key. Switches the LCD Backlight on and off.
- (7) Battery Level Indication
The battery icon flicker when battery gets low.
- (8) Numeric display. Indicates the receiver response to a signal.
- (9) Signal Strength. Indicates the strength of signal.
- (10) Gain. Signal gain-setting value.
- (11) Speaker Volume. Shows speaker volume (off, low, mid, high).
- (12) Selected Frequency indication. Displays selected frequency.

Battery and Charging

The Locator has built-in Li-Ion battery pack which has been installed in the battery box before delivery.

Recharge the battery with the supplied charging cable.

Open the rubber protection on Locator. Plug the charging cable type-c connector in charging input jack. Plug the other end into a 5V DC power adaptor. Close the rubber protection cover when charging finished.

Charging indicator LED will be red during charging. The LED will be off when charged fully. Charging indicator LED flashes when battery or power adaptor fail.

Notes:

If not use in a long term, take a recharge per 6-month, to ensure the battery in normal working status.

Do not use the Locator when charging.

Ideally, the battery pack should be charged at an ambient temperature of between 0°C and 40°C .

Magnetic field signal

The locator receives magnetic field signals and displays their intensity. Typically, peak or valley values are obtained to determine the position and direction of the pipeline.

The transmitter and the power cables have different spatial magnetic field distributions.

Magnetic field of sonde

When the locator is positioned fixedly, aligning its blade parallel to the transmitter results in the maximum signal, while aligning it vertically yields the minimum signal.

Usually, keeping it parallel is the initial step to obtain peak signal, as shown in the diagram.

Move Locator forward and backward

Move Locator left and right

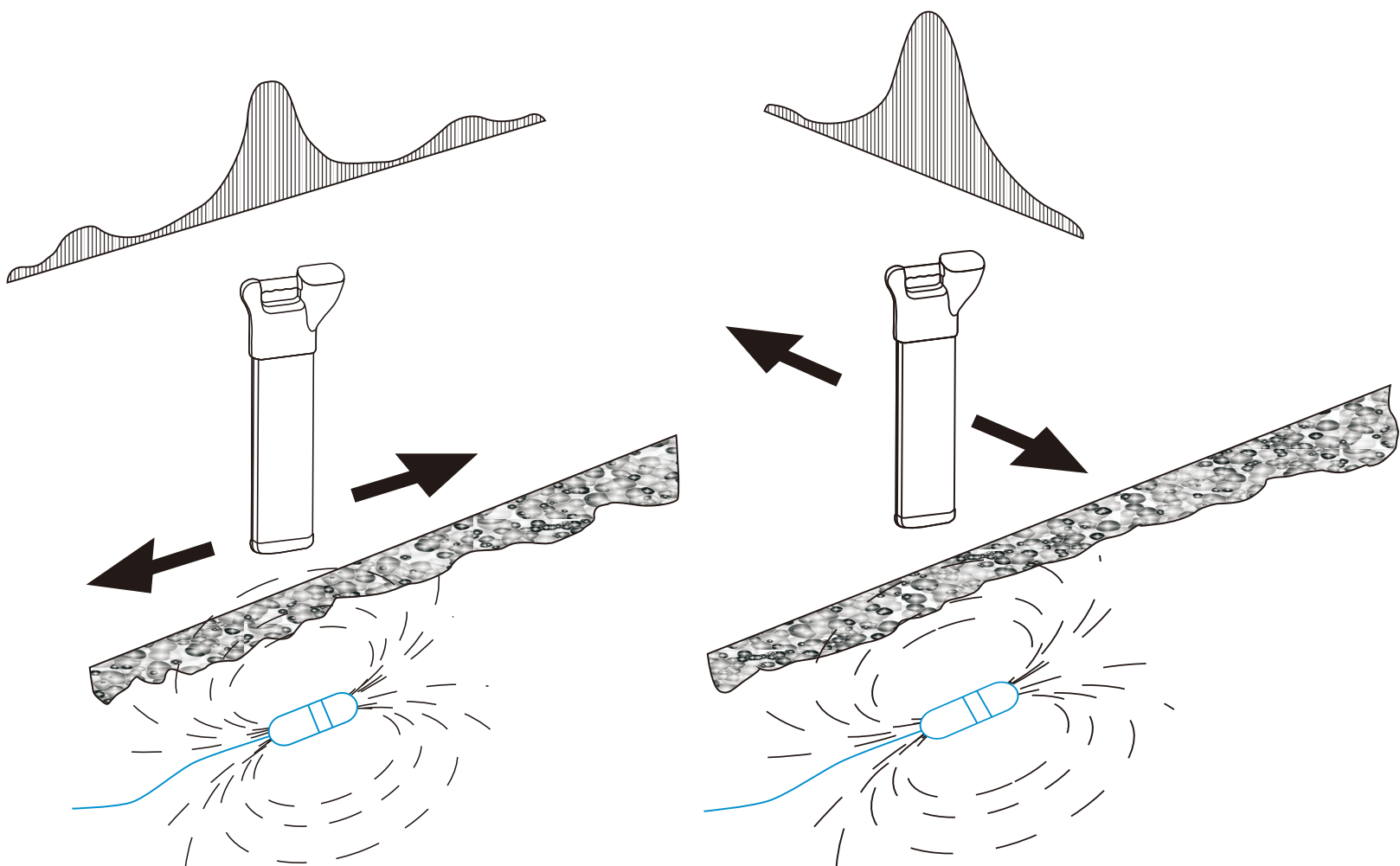

Magnetic field of power cable

When the locator is positioned fixedly, aligning its blade parallel to the transmitter results in the maximum signal, while aligning it vertically yields the minimum signal.

Usually, keeping it parallel is the initial step to obtain peak signal, as shown in the diagram. p to obtain peak signal, as shown in the diagram.

Move Locator forward and backward

Move Locator left and right

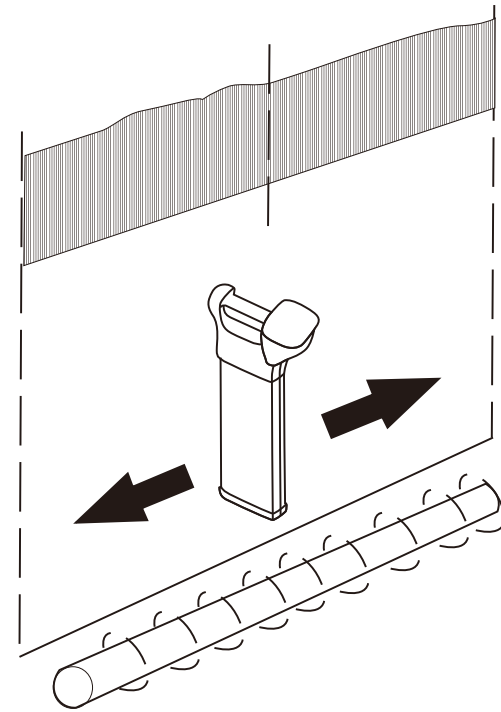
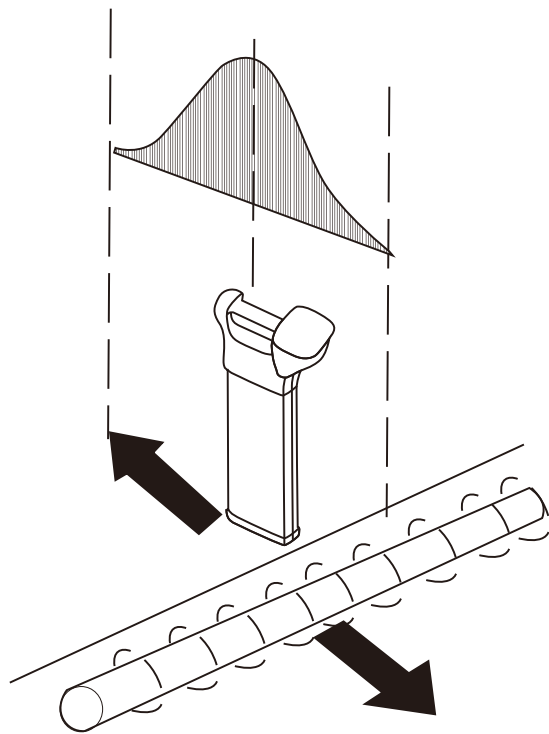

Use with sonde

Before inserting the probe into the pipeline, check if the locator and transmitter are on the same frequency and functioning properly.

Detect and track a sonde

Push the probe into the channel entrance of the pipeline and use the locator for positioning. Ensure the locator's blade is oriented vertically above the transmitter. Adjust the sensitivity of the locator to maintain the signal strength between 60% and 80% on the display.

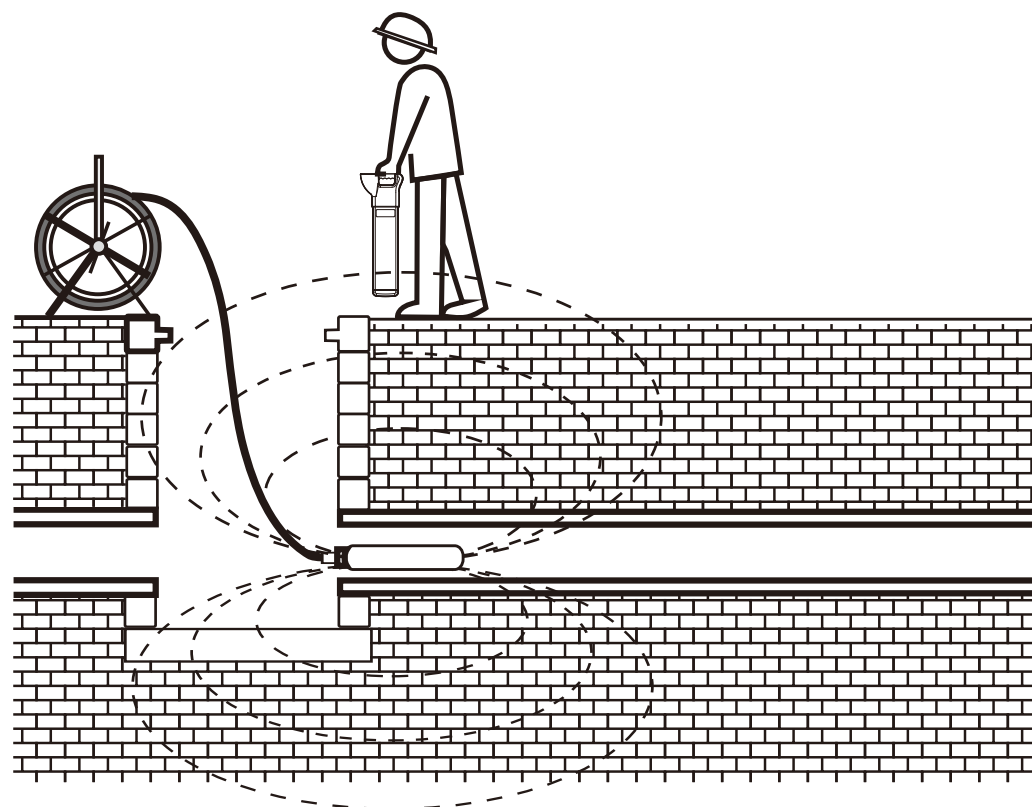

There is a peak response along the transmitter's central axis, with secondary peak responses on either side. Move the locator a certain distance and then advance it forward along the central axis of the transmitter to detect the secondary peak responses. Locate both secondary peak responses to confidently confirm the transmitter's position. Lower the sensitivity of the locator to make the secondary peak responses disappear, while maintaining a clear peak response directly above the transmitter.

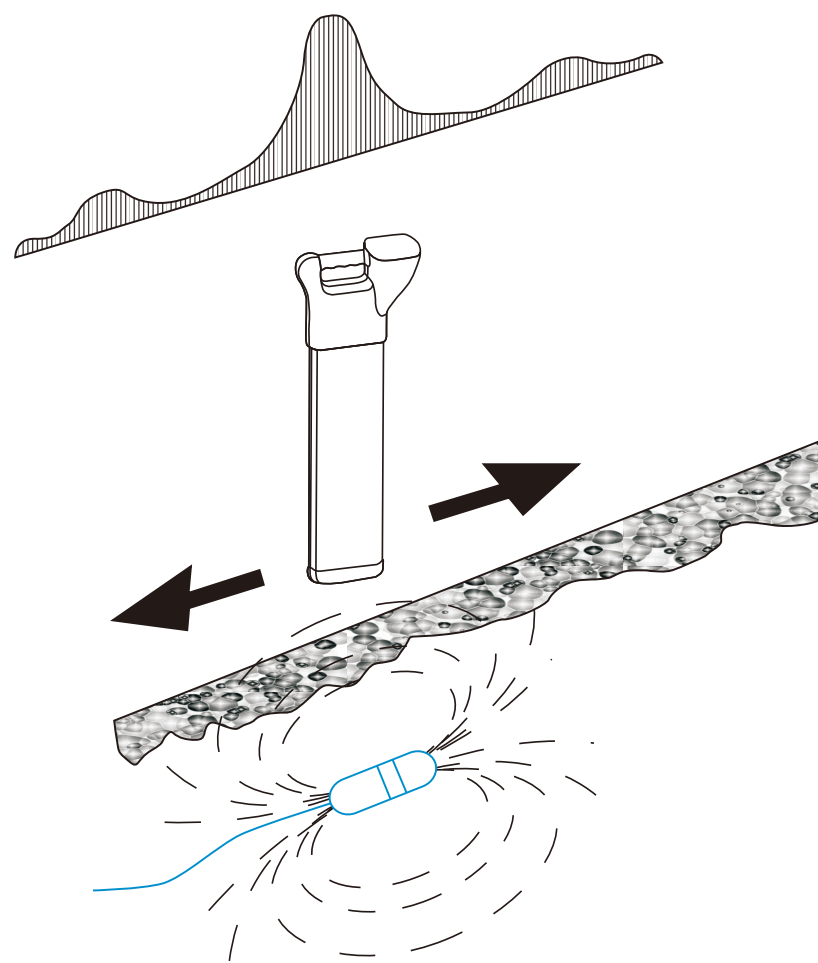

Now, fix the locator's sensitivity and track the drainage pipe or cable trench until the distance between the locator and transmitter changes.

After pushing the transmitter forward three steps along the drainage pipe or cable trench, come to a stop. Position the locator at the estimated location without adjusting its sensitivity.

1. Move the locator back and forth: Maintain alignment between the locator's internal antenna and the transmitter's direction. Stop when you detect the peak response.
2. Rotate the locator in place: Stop when the display reading reaches its maximum.
3. Move the locator left and right until you locate the peak response.
4. Keep the antenna vertical, place the locator on the ground, and repeat steps 1, 2, and 3. At this point, the locator should be directly above the transmitter, with the antenna aligned with the transmitter's direction. Mark the transmitter's position and direction on the ground.
5. Push the transmitter forward three to four steps for precise positioning and mark the transmitter's location. Repeatedly perform accurate positioning of the transmitter along the drainage pipe or cable trench at roughly equal intervals.

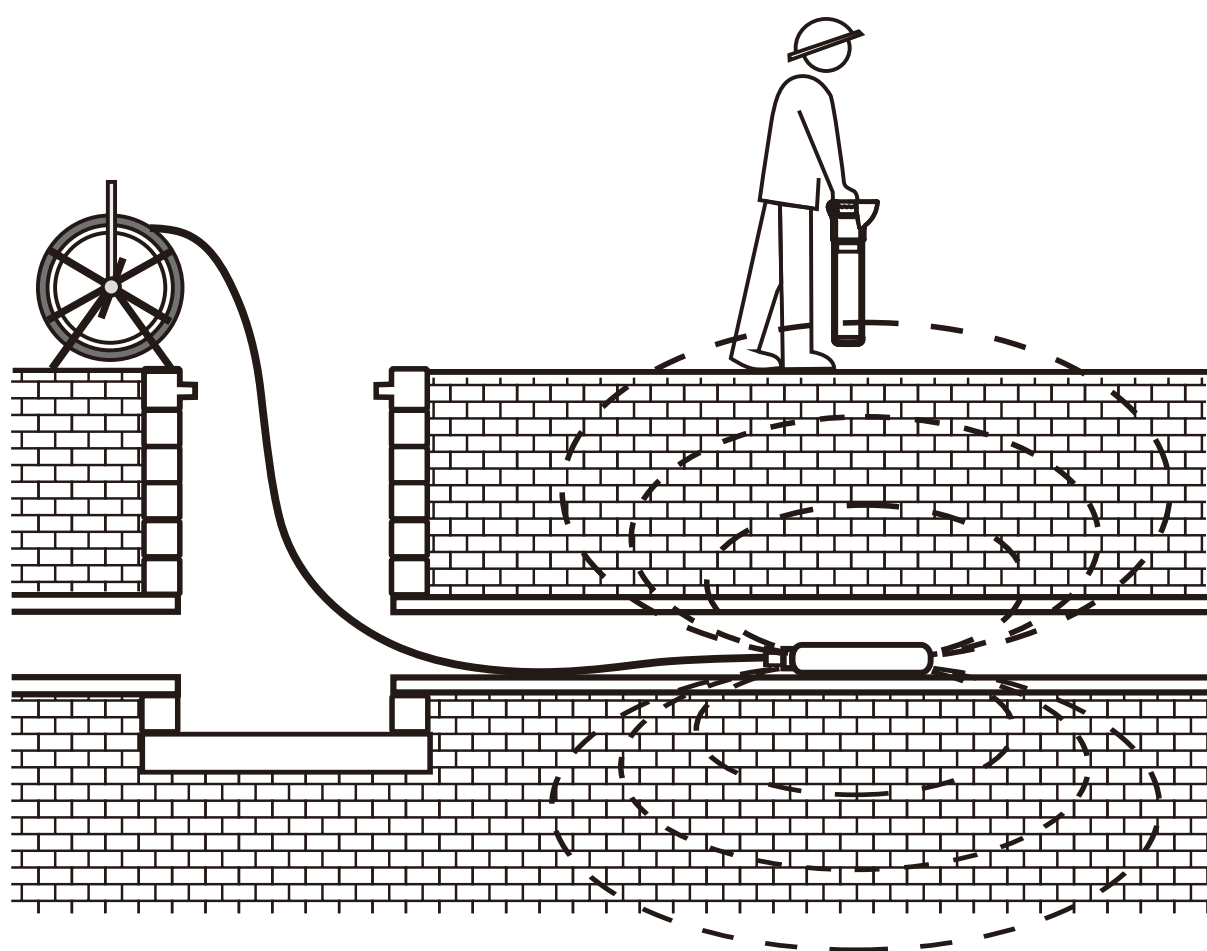

Determining the depth of sonde by calculation

Following the above steps for precise positioning of the transmitter, move the locator forward while maintaining antenna alignment with the transmitter's direction.

Increase sensitivity to locate the secondary peak response. Move the locator to the rear of the transmitter probe while keeping the locator's body aligned with the transmitter probe's direction to find the valley response positions A and B. Measure the distance between A and B, then multiply this distance by 0.7 to estimate the approximate depth of the transmitter probe.

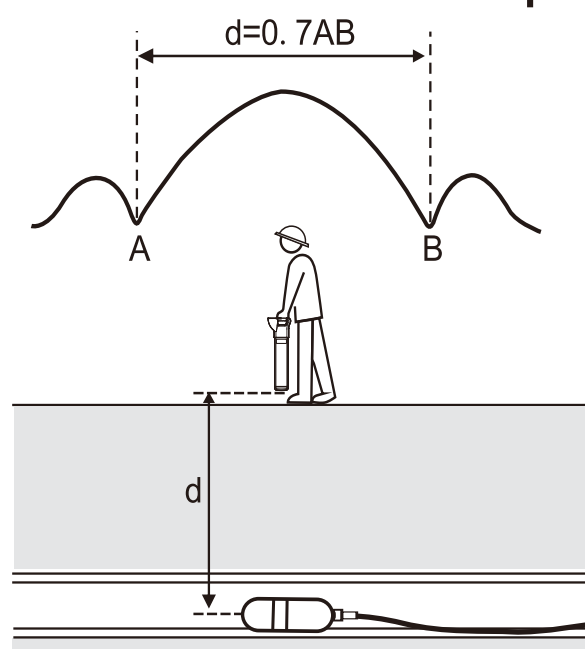

Power cable Location

Set the locator to Power-50Hz mode (for regions with a power frequency of 50Hz, suitable for China and Europe) or Power-60Hz mode (for regions with a power frequency of 60Hz, suitable for the United States and Japan). Adjust the gain (sensitivity) to the maximum level and reduce sensitivity when encountering a strong signal, ensuring that the response remains within the scale range on the display. Walk along a grid-like route, maintaining a steady pace, and keeping the locator's antenna perpendicular to any potential pipelines that may be crossed.

When the locator's response increases, indicating the presence of a pipeline, stop and rotate the locator in place. Stop when the response is at its maximum, keeping the locator vertical to the ground. Move the locator back and forth, left and right above the pipeline until the response is maximized again, then mark the position of the pipeline. Follow the pipeline until it exits the search area. Then continue with the grid-like search within the area.

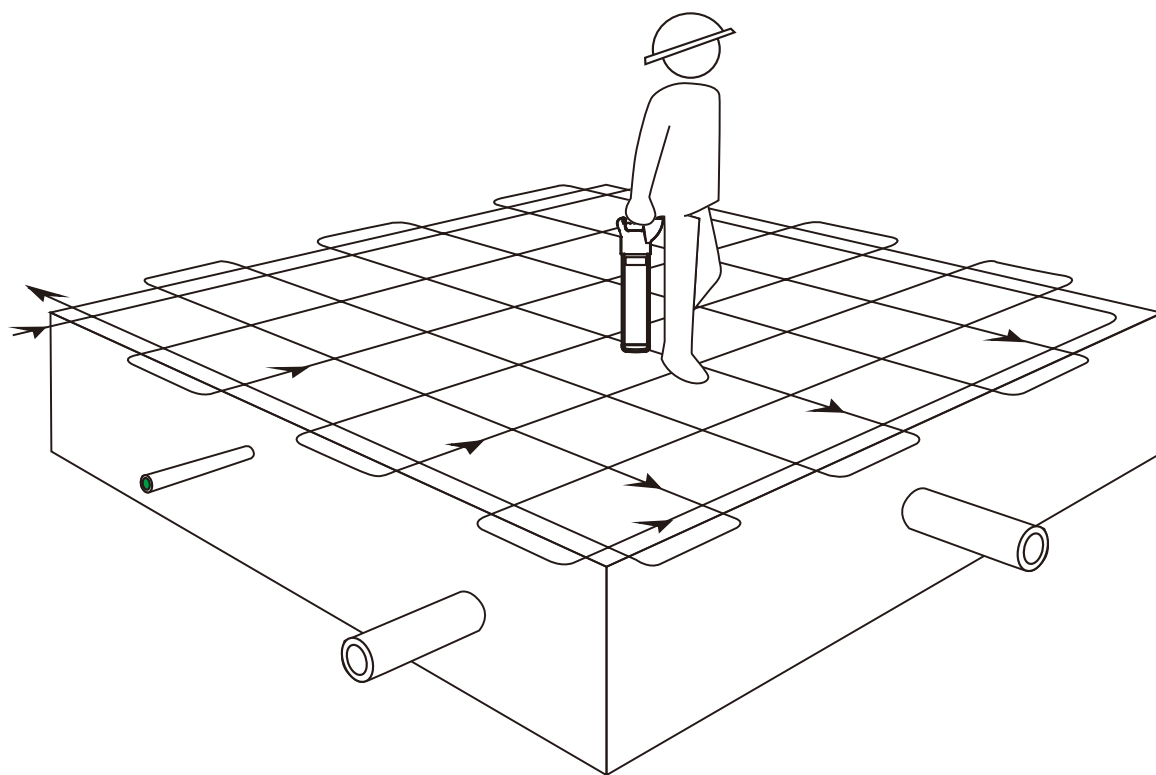

In some areas, there may be interference from 50/60Hz power signals. In such cases, raise the locator approximately 5 centimeters (2 inches) above the ground and continue the search. Alternatively, switch the locator to the Radio mode and repeat the grid-like search and precise positioning as mentioned earlier, marking the positions of all pipelines.

In most areas (but not all), the Radio mode can detect pipelines that do not emit power signals. Therefore, you can use both Radio and Power-50Hz/Power-60Hz modes for grid-like searching and positioning within a given area.